

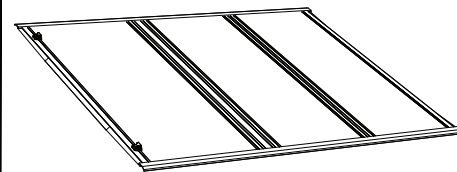

# Tri-Fold Tonneau Cover



**Fits:** TFX5528 - Toyota Tundra 5.5' bed - 2022 W OR W/O Cargo Management System  
 TFX5529 - Toyota Tundra 6.5' bed - 2022 W OR W/O Cargo Management System



30-60 min



Cutting Not Required



Drilling Not Required



THE TRAILFX TRI-FOLD TONNEAU COMES FULLY ASSEMBLED.



REMOVE CONTENTS FROM BOX. VERIFY ALL PARTS ARE PRESENT.



READ INSTRUCTIONS CAREFULLY BEFORE STARTING INSTALLATION.



DO NOT OVER TORQUE. A TORQUE WRENCH IS NOT NECESSARY. IF PREFERRED, TORQUE IS APX 120 INCH LBS.

[support@trailfx.com](mailto:support@trailfx.com)

1 866 638 4870

**LIMITED LIFETIME WARRANTY**

# KS-C5

### PARTS LIST OF COMPONENTS

PN	Part Description/ Qty	PN	Part Description/ Qty
1	Hard Folding Cover (1)		
2	Driver (Left) Mounting Rail (1)		
3	Passenger (Right) Mounting Rail (1)		
4	Standard Clamp Kit (6)- For use without Cargo Mgnt System		
5	Track Clamp Kit (6)- For use with Cargo Mgnt System		
6	Cover Retainer Clamps (4)		
7	Drain Tubes (2)		

### Components

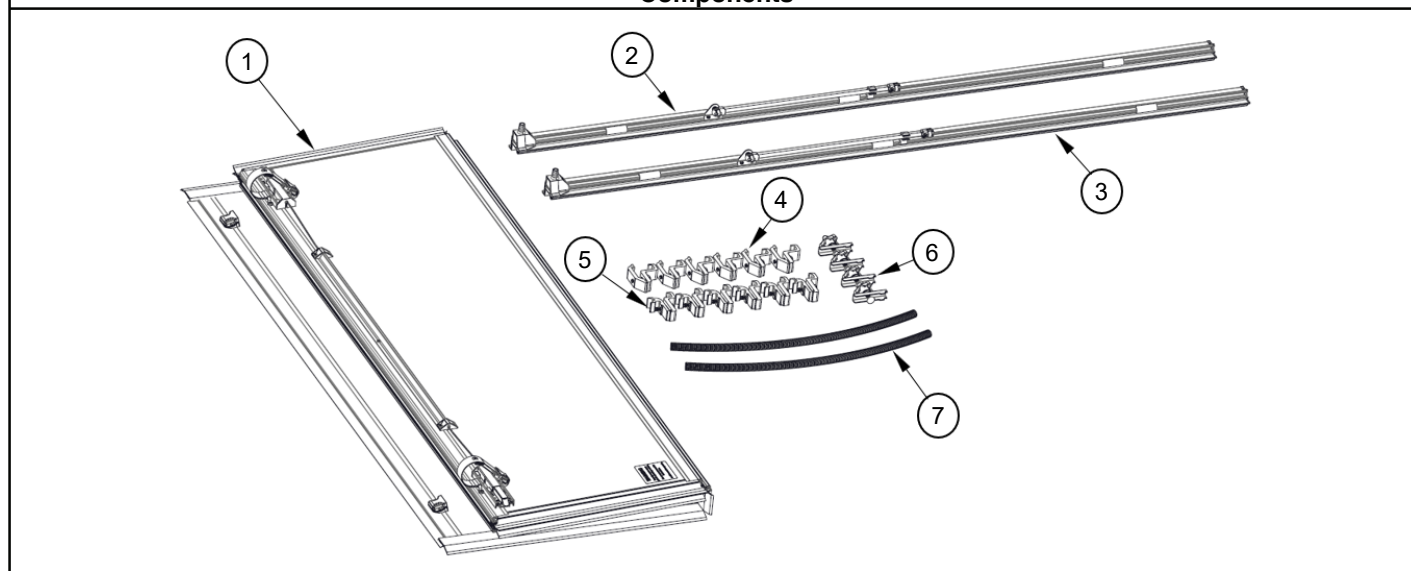

### Tools Required

Ratchet & 1/2" Socket



## INSTALLATION PROCEDURE: Attaching Side Mounting Rails (W/O Cargo Management System)

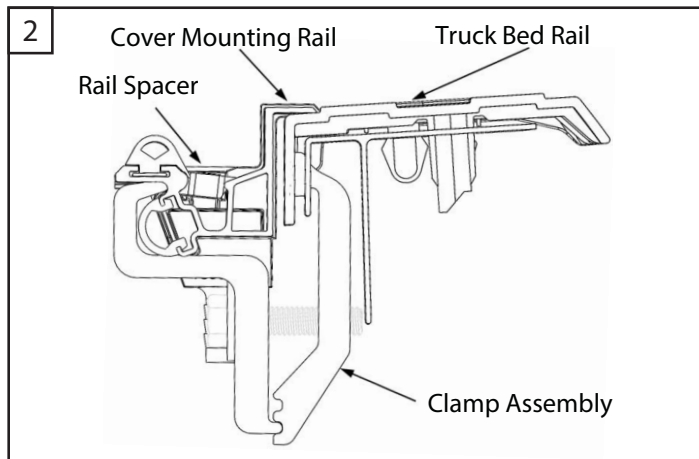
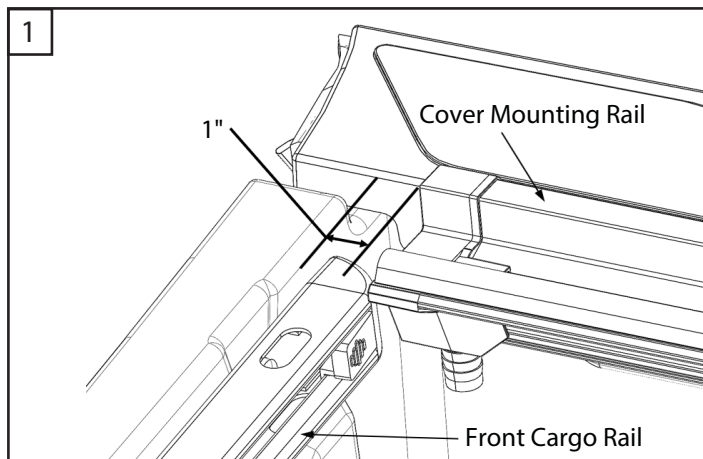

1. Attach both left and right side rails to the truck bed. The end of the mounting rail with the drain tube fitting will go towards the cab of the truck.

2. Measure 1" back from the inside face of the front bulkhead and position the top L shaped portion of the mounting rail on the top of your truck bed rail, Figure 1 & 2.

3. Using three (3) clamps per side attach the mounting rail to the bed, position the clamps adjacent to each of the black clamp spacers, Figure 3. (Tip: Mount the center clamp first but do not tighten completely. This will give you the ability to adjust the rail as the outer clamps are attached).

4. Tighten the clamps using a 1/2" wrench or socket.

Note: If you discover your truck will not allow you to position a clamp adjacent to the spacer, simply slide the spacer forward or back as needed.

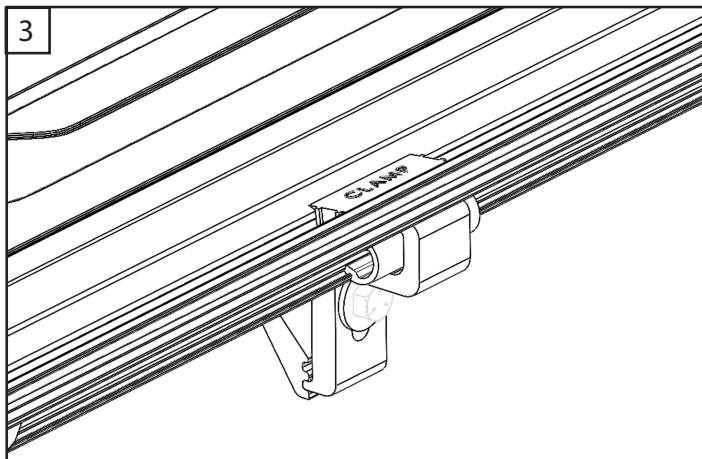

**Warning!** Do not overtighten the clamp assembly. A torque wrench is not necessary. If preferred, torque is approx. 120 inch lbs.



**Warning!** Clamps must be checked periodically for tightness. Failure to do so could result in damage to you or your property.

## INSTALLATION PROCEDURE: Attaching Side Mounting Rails (W/ Cargo Management System)

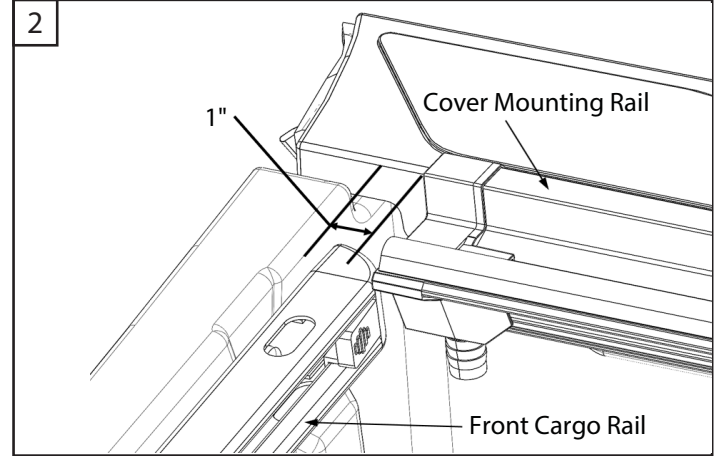
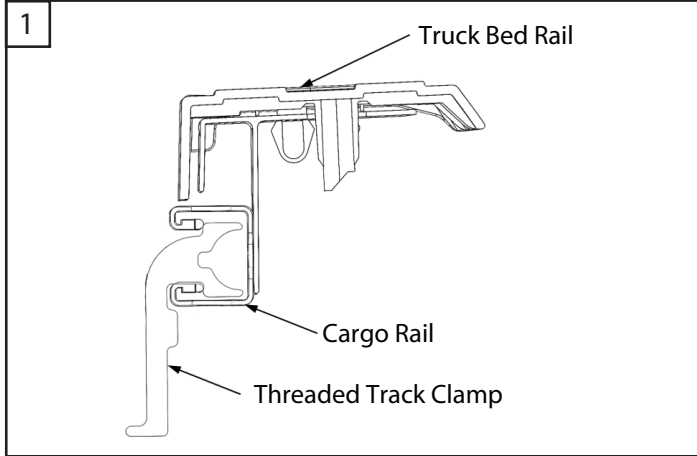

1. Slide the threaded portion of the track clamp (3 per side) into the Cargo rail, position one front, one center and one rear, Figure 1.

2. Place both left and right side rails on top of the truck bed rail. The end of the mounting rail with the drain tube fitting will go towards the cab of the truck. Measure 1" back from the inside face of the front bulkhead and position the top L shaped portion of the mounting rail on the top of your truck bed rail, Figure 2. Install the remaining slotted portions of the clamps, bolts and washers, three (3) per side attaching the mounting rail to the bed rail.

3. Position the clamps adjacent to each of the black clamp spacers, Figure 3. (Tip: Mount the center clamp first but do not tighten completely. This will give you the ability to adjust the rail as the outer clamps are attached)

4. Tighten the clamps using a 1/2" wrench or socket.

Note: If you discover your truck will not allow you to position a clamp adjacent to the spacer, simply slide the spacer forward or back as needed.

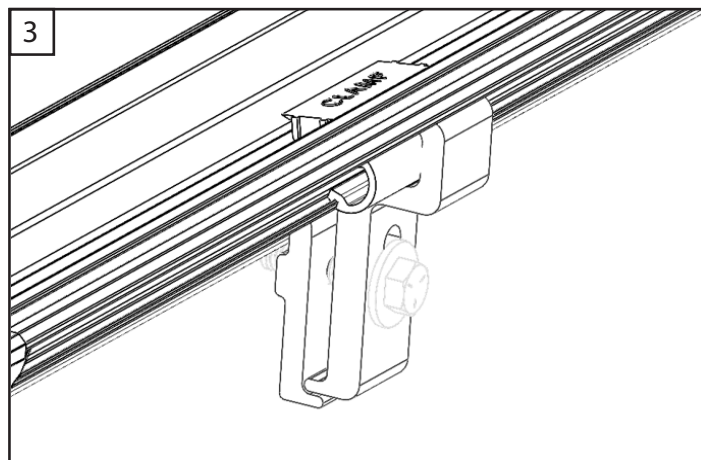

**Warning!** Do not overtighten the clamp assembly. A torque wrench is not necessary. If preferred, torque is approx. 120 inch lbs.



**Warning!** Clamps must be checked periodically for tightness. Failure to do so could result in damage to you or your property.



5. Set the tonneau onto the mounting rails, the buckles should be to the front.

**Correct**

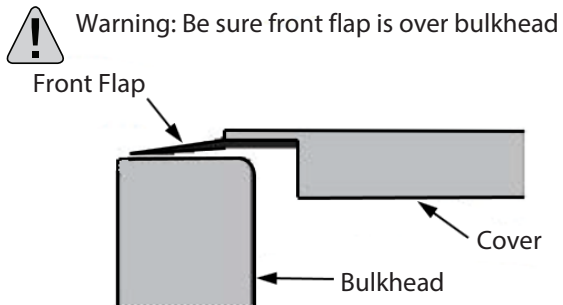

**Incorrect**

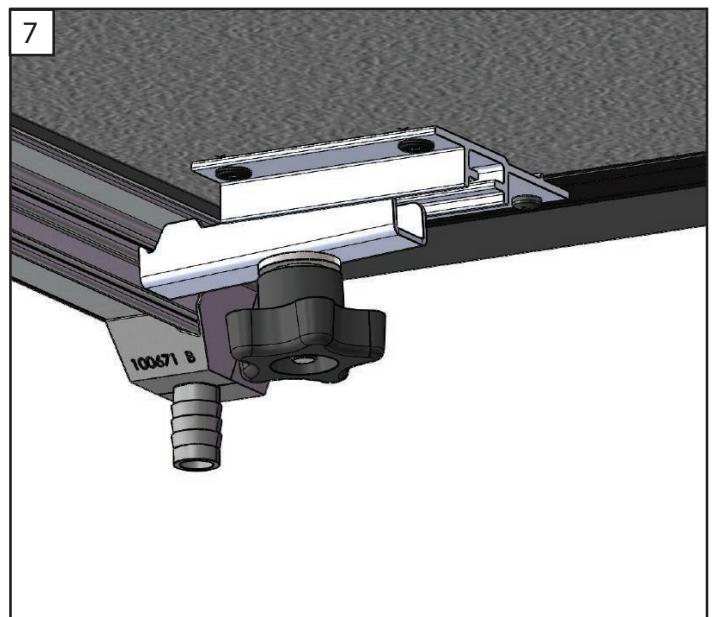
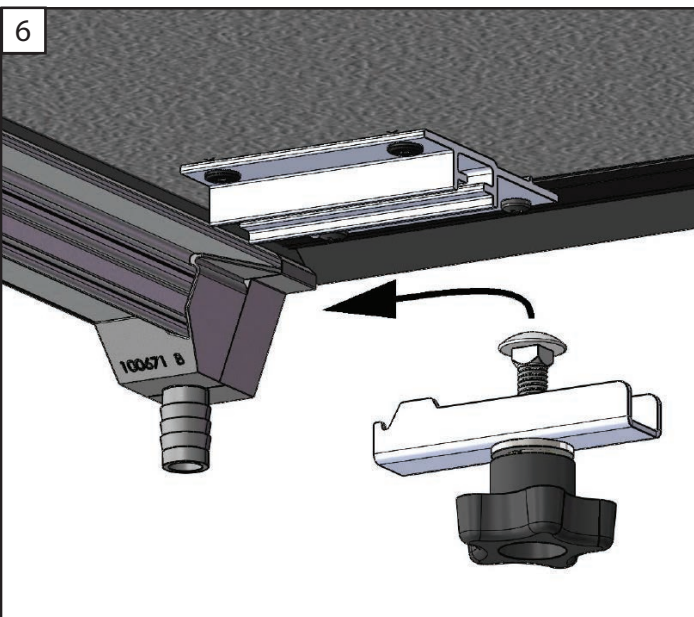
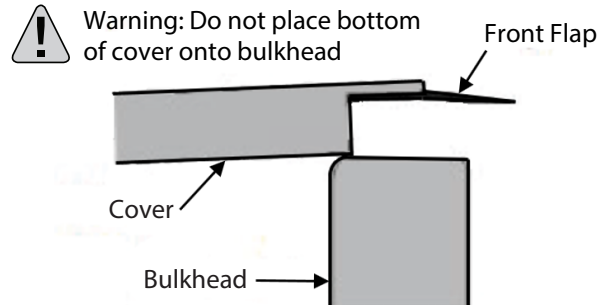

6 & 7. Assemble the four retainer clamps, slide each of them into the track on the underside of the tonneau, slide into position, but do not tighten at this time.

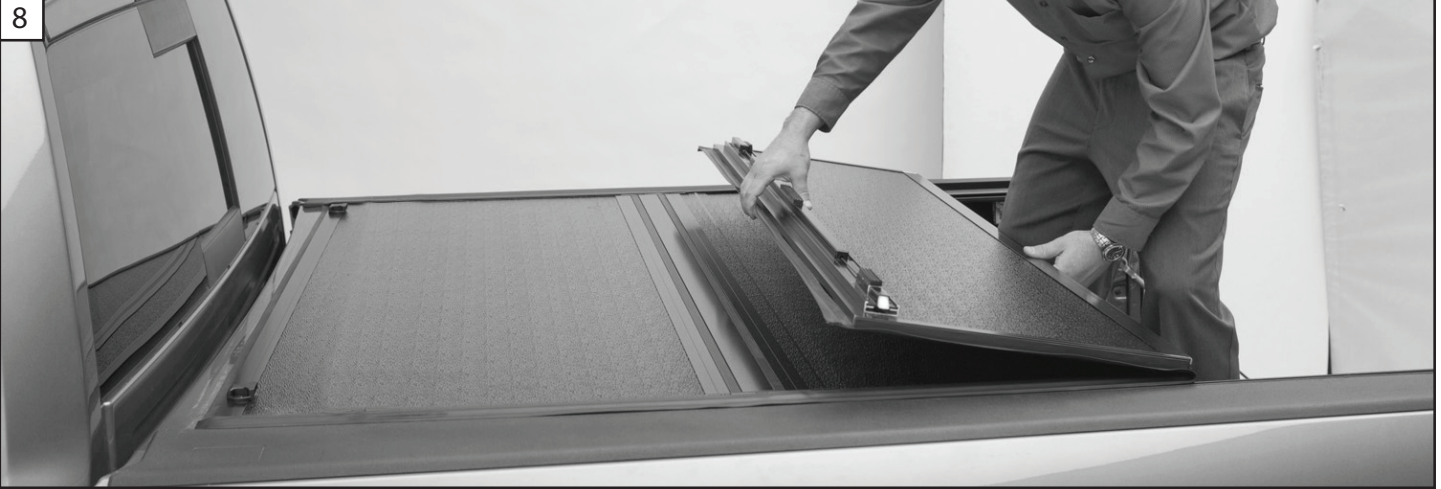

8. Carefully unfold the cover. Position the cover so it is centered side to side and front to back on the truck bed.

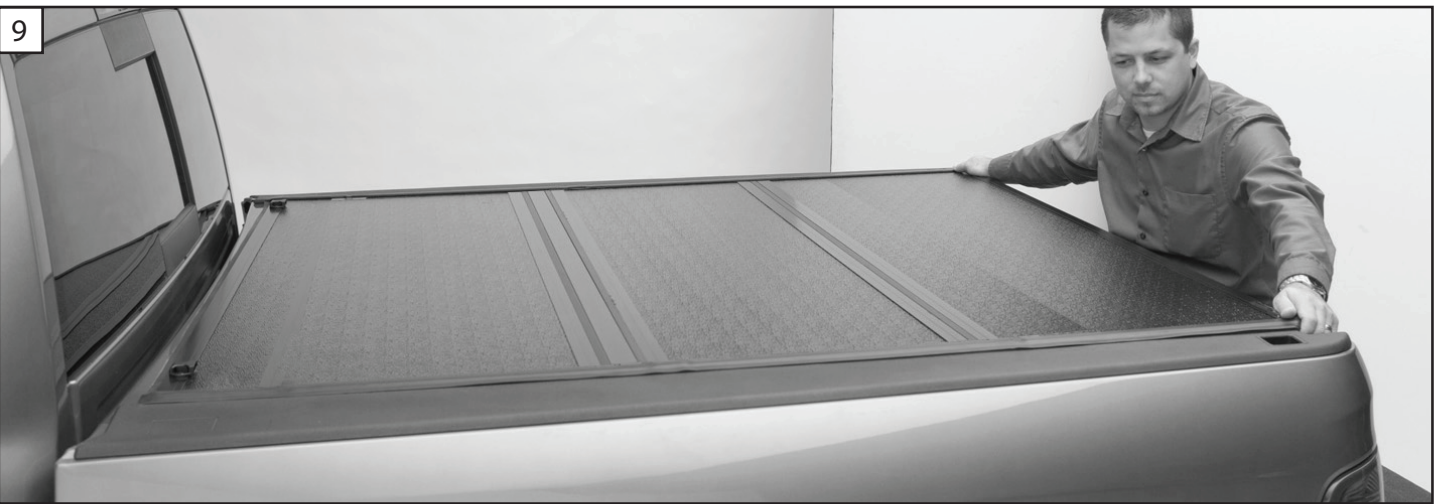

9. Test the rear latching assembly for smooth operation as this is the best indicator of the cover being positioned correctly. Be sure the latches on both sides are engaging with the cover mounting rail.

*Note: If your truck is equipped with a tailgate protector, you may need to slightly raise the rear of the side mounting rails for the latches to engage properly.*



10 & 11. Once the cover is located correctly, fold the cover to the open position. Pull the release cables on the rear panel to release it from the side rail. Take care to fold it gently so the position of the cover is not disturbed.

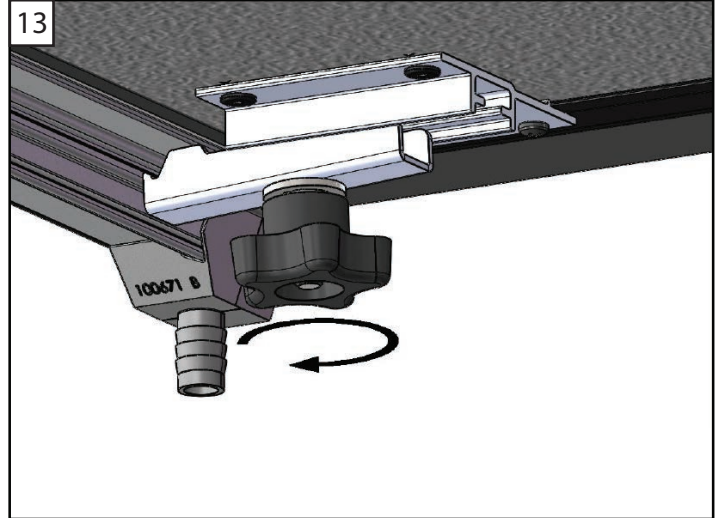
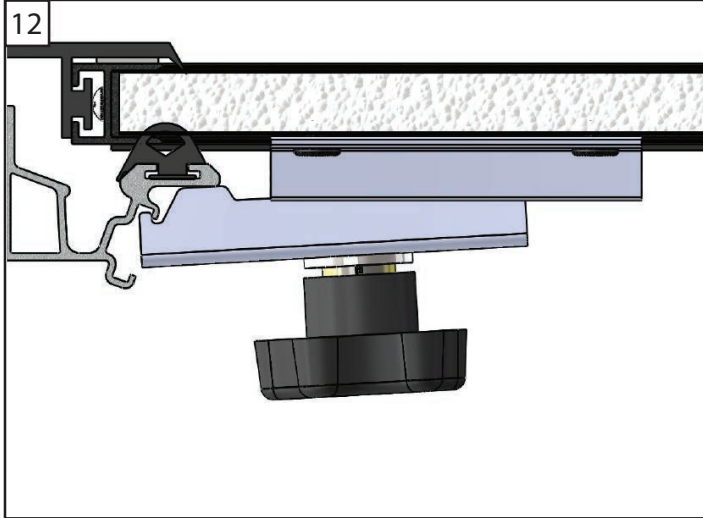

12 & 13. Once in the open position double check the clamp engagement to the side rail and tighten. Test the cover again for proper operation, adjust as needed, then tighten the star knobs.

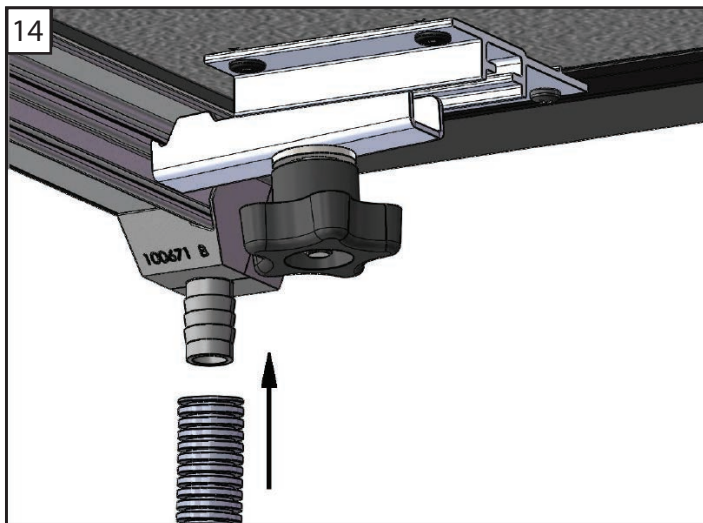

14. Attach the drain tubes to the fittings at the front of the bed rail and position the tubes to divert water out of the truck bed. This can be done by placing the tube through an existing hole in the bed, or by drilling a 5/8" hole in the bulkhead or bed floor.

**Note:** If you choose to drill holes, check to make sure the area is free and clear of any obstructions below/ behind the bed. Be sure to clean up metal shavings.

## OPERATION INSTRUCTIONS



1 & 2. To open the cover: Lower the tailgate and pull the cable. While pulling on the cable lift the panel up and towards the cab.

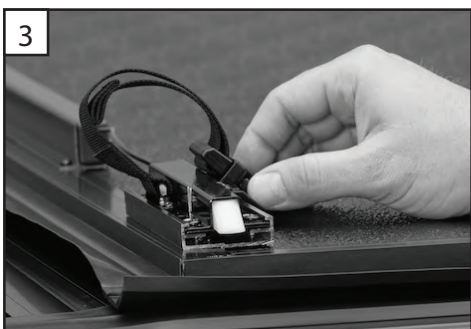

3, 4 & 5. Release the strap from the stowed position by squeezing the tabs. Attach the buckle at the bulkhead, pull the strap to take up the slack and secure the cover. Repeat this for the opposite side.

## PRODUCT CARE

- Clean with soap and water only.
- Cover must be secured when vehicle is in motion. See instructions for recommended driving positions. An unsecured cover can result in damage not covered by this warranty.

## WARRANTY COVERAGE

Keystone Automotive Operations Inc. (KAO) warrants this product to be free of defects in material and workmanship at the time of purchase by the original retail consumer. KAO disclaims any other warranties, express or implied, including the warranty of fitness for a particular purpose or an intended use. If the product is found to be defective, KAO may replace or repair the product at our option, when the product is returned prepaid, with proof of purchase. Alteration to, improper installation, or misuse of this product voids the warranty. KAO's liability is limited to repair or replacement of products found to be defective, and specifically excludes liability for any incidental or consequential loss or damage. The repaired or replaced tonneau will be in warranty for the remainder of the original warranty period.

## FAQ:

1. How difficult is it to install the tonneau cover?

***Installing of tonneau cover is easy, please follow the steps in installation manual carefully.***

2. How do I clean my tonneau cover?

***Wash the tonneau same as your truck. We recommend using soap and water.***

3. Will the tonneau cover scratch my paint?

***No. Please follow the installation instruction manual carefully to avoid scratching paint.***

4. Missing or Excess Hardware?

**Re-check hardware count as per the part list.**

5. Why is my tonneau cover not installing properly?

**Ensure year, make, model, cab length and bed size of your vehicle is listed in the application and installation steps are followed correctly.**

## CHECK OUT THESE OTHER TRAIL FX PRODUCTS!

